

PROMOTIONAL DISPLAYS



nimlok

WORLD LEADING DISPLAY SYSTEMS



GRAPHIC D



Graphic Displays

Your message stands out loud and clear, and can be updated as often as needed. Graphic panels slide in and out by simply unscrewing a single extrusion, and replacing it once you've made the switch.

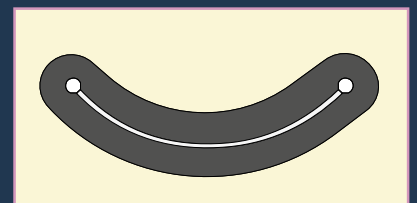

Think Smart.

Think Fast.

Think Nimlok Promotional Displays

Introducing the brand new range of promotional displays, from the recognised leader in the display and exhibition industry.

The Nimlok Promotional Display System meets a range of needs with an economical and practical modular approach. Whether you need one graphic display for a test market application, or multiple displays for a national campaign, Nimlok's numerous design options offer simple assembly, completely changeable graphics and messages, and reconfiguration options for future applications.

All of the Nimlok Promotional Displays are constructed of our rugged aluminium extrusion system, and are available in the kits shown on the following pages, or can be custom designed to your specific requirements.

2400mm

1200mm

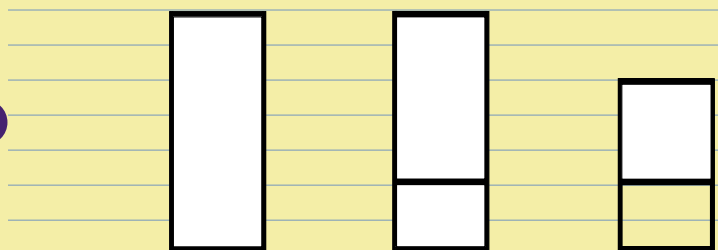

nimlok

Think Smart.

ISPLAYS

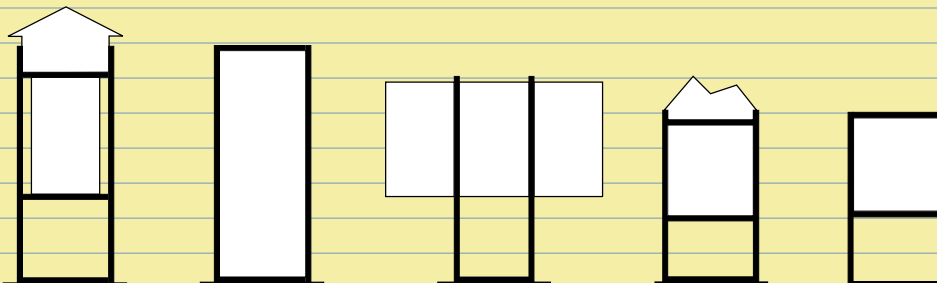
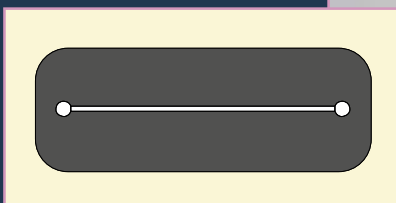

BACKLIT DISPLAYS

PRODU

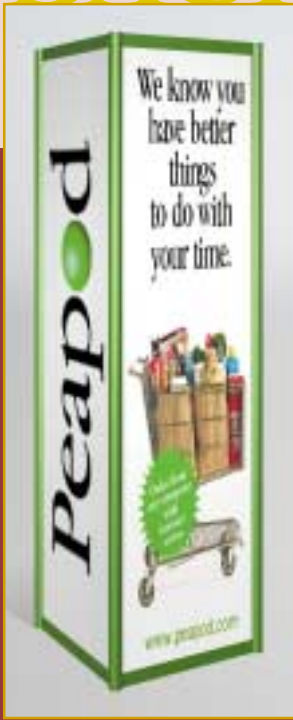

Backlit Displays

Backlighting in these high-impact displays creates a dramatic presence, ensuring your message is seen and remembered. You can also opt for the same graphic display without backlighting.



2400mm

1200mm

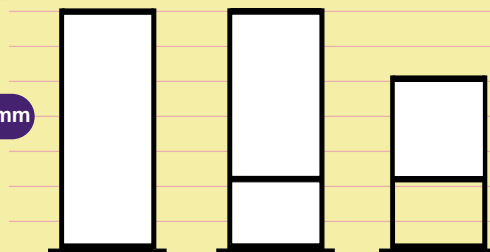

nimlok

CT DISPLAYS Think Fast.



Product Displays

Nimlok's rigid extrusion system creates the ideal product display. Our designers can customise a solution for any product, whether you require one display or 100.

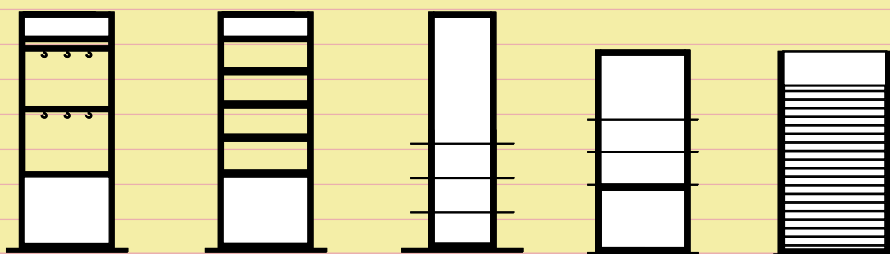

COMPUTER KIOSKS

Think Nimlok.



Computer Kiosks

An interactive information centre is one of the best ways to keep current information in front of your customers. Graphics on these kiosks are also easily updated.



2400mm

1200mm

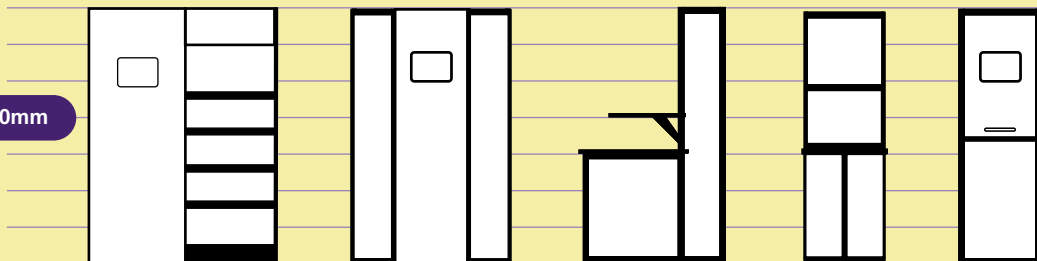

nimlok

KIOSKS

SHOWCASES



Kiosks

Optimise valuable retail space with Nimlok's modular extrusion system. You can create an unlimited number of functional kiosk designs, for any space or product requirement.



Showcases



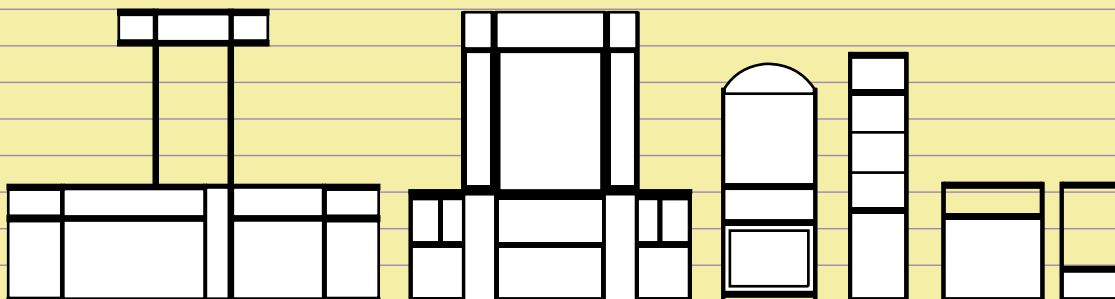









Elegant showcases can be finished in your choice of laminate or graphic panels, for a completely unique presentation.

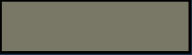

KITS

These kits are available in the configurations shown. The standard finish is black powdercoat with black melamine bases. We also offer bases in a range of laminates. Extrusions are available in the powdercoated finishes shown.

STANDARD COLOURS

			
3020	6001	4005	9005
			
2009	5010	7031	9010
			
1023	5012	BS00A05	Anodised

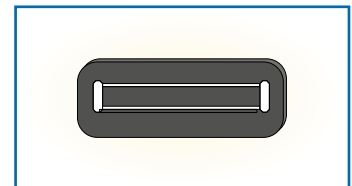
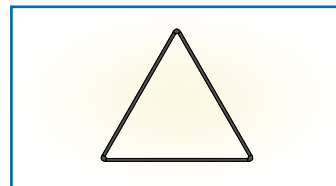
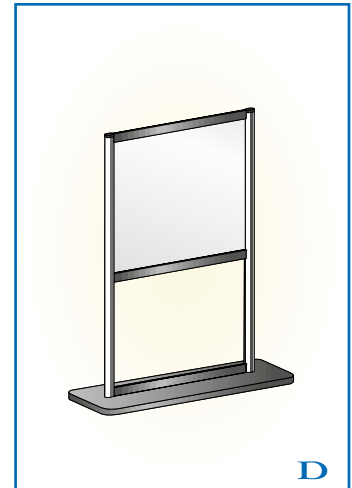
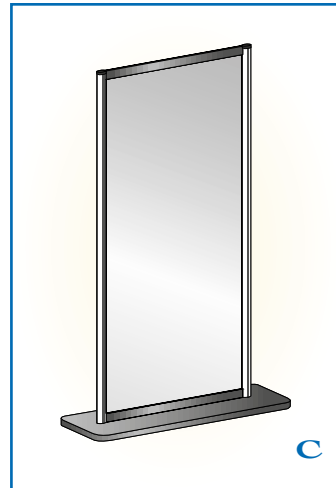
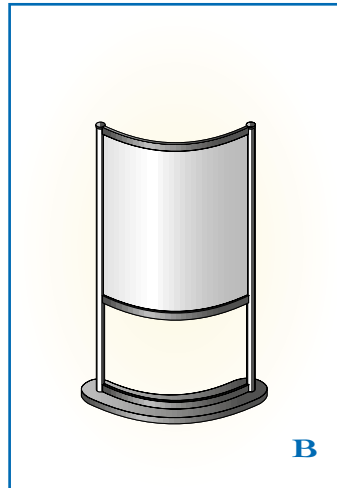
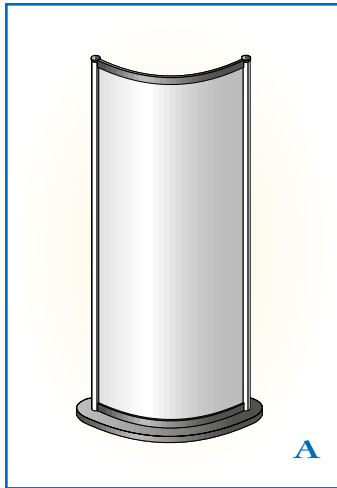

Graphic Display kits are available 1500mm or 2100mm high. Units A and B feature a curved graphic display upon a kidney shaped base. Units C and D display a conventional flat graphic on a rectangular base.

Backlit Display kits E, F, and G are 2100mm high. Unit H is 1800mm high. All kits are also available non-backlit.

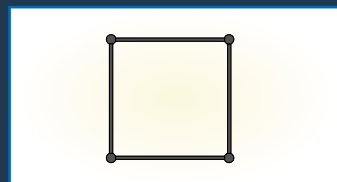
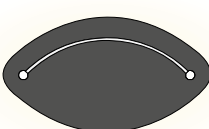
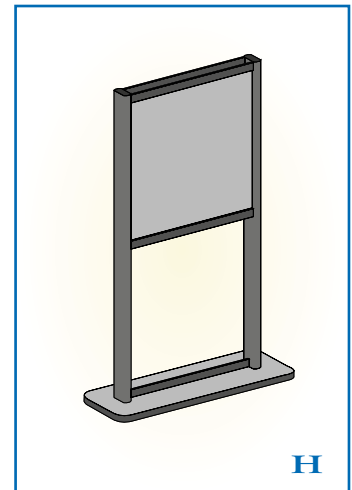
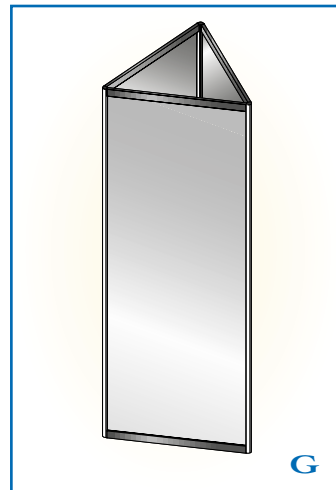
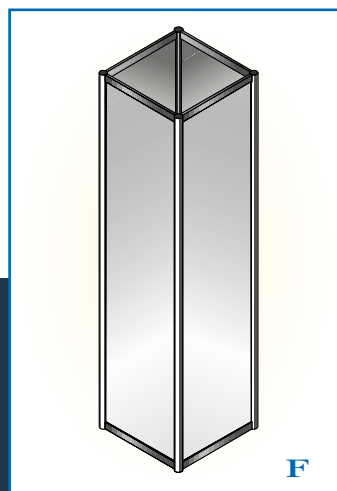
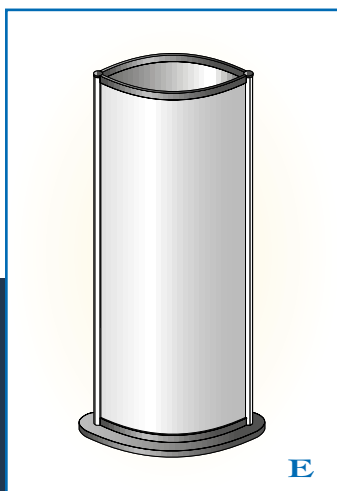

DISTRIBUTOR:

nimlok

Nimlok Ltd., Nimlok House, Booth Drive, Park Farm, Wellingborough, Northants NN8 6NL, UK.
Telephone: 01933 409409 Fax: 01933 409452 e-mail: info@nimlok.co.uk